



# ST-P

## “Plunger Piston Motor-driven pumps”

The metering pumps ST-P series are driven by an electric motor, the dosage takes place thanks to a piston. The ST-P series pumps make their robustness and reliability their main characteristic.

### General Features

- Working Frequency: from 60 to 120 strokes/min at 50Hz - from 72 to 144 strokes/min at 60Hz
- Die-cast aluminum housing protected by epoxy/antiacid paint
- Max Flow Rate: 190 l/h at 50Hz - 114 l/h at 60Hz
- Standard Power Supply: 230-400V 3phases 50/60Hz
- Pump Head: PVC, SS316L or PVDF
- Valves: Balls in ceramic or SS316L
- Ball seats: FPM, EPDM or NBR
- Valve seats in PVC or PVDF
- Piston in SS316 or Ceramic
- Piston seals NBR, FPM or EPDM
- Max Pressure: 20 bar
- Motor: 0.18 kW
- IP55 protection degree
- F insulation class

Code	Flow rate	Delivery Head AISI
	l/h (US Gal/h)	bar (psi)
AP0011AA00100	11 (2,91)	20 (290)
AP0022AA00100	22 (5,81)	20 (290))
AP0039AA00100	39 (10,30)	13,5 (196)
AP0077AA00100	77 (20,34)	10 (145)
AP0095AA00100	95 (25,10)	4.5 (65)
AP0190AA00100	190 (50,20)	3.5 (51)

Code	Flow rate	Delivery Head PVC
	l/h (US Gal/h)	bar (psi)
AP0011BA00100	11 (2,91)	10 (145)
AP0022BA00100	22 (5,81)	10 (145)
AP0039BA00100	39 (10,30)	10 (145)
AP0077BA00100	77 (20,34)	10 (145)
AP0095BA00100	95 (25,10)	4.5 (65)
AP0190BA00100	190 (50,20)	3.5 (51)

### On request

ST-P pumps series can be equipped with

### Motorizations:

- Without motor • UL/CSA motor certification • Single-phase motor • Self-ventilated motor
- ATEX motor • Tropicalized motor

### Hydraulic:

- NPT hydraulic connections • Larger dimensions valves

### Regulation and control by an external signal:

- Electric actuator (automatic adjustment of piston “run” by a 4-20mA signal) • Inverter (automatic adjustment of motor speed by a 4-20mA signal)

### Technical Features

Model	Flow rate l/h (US Gal/h)		Delivery Head bar (psi) AISI		Delivery Head bar (psi) PVC		Strokes/min		Stroke length mm	Ø Diaphragm mm	Power kW	Valves
	50 Hz	60 Hz	50 Hz	60 Hz	50 Hz	60 Hz	50 Hz	60 Hz				
AP0011 AP0022	11 (2,91) 22 (5,81)	13 (3,49) -	20 (290) 20 (290))	20 (290) -	10 (145) 10 (145)	10 (145) -	60 120	72 -	15 15	16	0,18	1/2" Gm
AP0039 AP0077	39 (10,30) 77 (20,34)	47 (12,36) -	13,5 (196) 10 (145)	11 (157) -	10 (145) 10 (145)	10 (145) -	60 120	72 -	15 15	30	0,18	1/2" Gm
AP0095 AP0190	95 (25,10) 190 (50,20)	114 (30,12) -	4.5 (65) 3.5 (51)	4 (58) -	4.5 (65) 3.5 (51)	4 (58) -	60 120	72 -	15 15	48	0,18	3/4" Gm

### Overall Dimensions

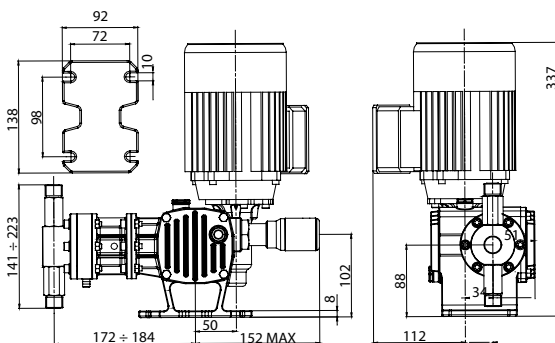

### Pump Head configurations

#### Standard

Version	Head	Connections	Piston	Piston Seals	Valve Seats	Balls	Ball Seats
AA	SS316L	SS316L	SS316L	NBR	PVDF	SS316L	NBR
CA	PVC	PVC	PTFE	Ceramic	PVC	Ceramic	FPM

#### On Request

Version	Head	Connections	Piston	Piston Seals	Valve Seats	Balls	Ball Seats
AP	SS316L	SS316L	SS316L	FPM	PVDF	SS316L	FPM
AI	SS316L	SS316L	SS316L	EPDM	PVDF	SS316L	EPDM
BA	PVC	PVC	Ceramic	FPM	PVC	Ceramic	FPM
BI	PVC	PVC	Ceramic	EPDM	PVC	Ceramic	EPDM
SA	PVDF	PVDF	Ceramic	FPM	PVDF	Ceramic	FPM
SI	PVDF	PVDF	Ceramic	EPDM	PVDF	Ceramic	FPM